

USB-3200 Series Multifunctional Data Acquisition Devices

User Manual

Rev. C

Smacq

Beijing Smacq Technology Co., Ltd.

smacq.com

smacq.cn

Statement

Copyright

©2018 Beijing Smacq Technology Co., Ltd. All rights reserved
No content of this manual may be reproduced, modified or abridged without prior consent and written permission.

Trademark information

Smacq is a registered trademark of Beijing Smacq Technology Co., Ltd.

The names of the other products and companies mentioned in this document are trademarks or trade names of their respective companies.

Other Disclaimer

- The information provided in this document may be modified and updated in subsequent versions without prior notice.
- Smacq does not provide any warranties, express or implied, for this document as well as the information inside it, including but not limited to implied warranties of the marketable nature of the product and its suitability for a particular purpose.
- There may be a chance that inaccurate descriptions or errors exist in this document. Smacq does not hold any liability for accidents because of the information and deductive functions provided in this manual, as well as the resulting loss of any chance because of the use of this document.
- Smacq reserves the rights to change product specifications, prices, and decide whether to stop the production.

Contact Us

If you have any questions or need assistance in using this product or this document, please contact us via:

Phone: (+86)10 - 52482802
E-Mail: service@smacq.com
Website: <http://www.smacq.com>
<http://www.smacq.cn>

Safety Requirements



Warning Only the voltage within the specified range can be connected. Voltage exceeding the specified range may cause damage to the device, and even present a negative impact on personal safety. Check the product specification for detailed reference to the range of voltages that can be connected by each port.



Warning Do not attempt to operate the device in other ways that are not mentioned in this document. Incorrect use of the device may be dangerous. In the event of device damage, the internal security protection mechanism will also be affected.



Warning Do not attempt to replace device components or change devices in other ways that are not mentioned in this document. Do not repair the device yourself in the event of a product failure.



Warning Do not use the device in an environment where an explosion may occur or where flammable flue or gas is present. If you must use the device in this kind of environment, please fit it into a proper case.



Warning While the device is running, all chassis covers and fill panels need to be closed.



Warning For equipment with exhaust vents, do not insert foreign objects into the vents or block air circulation in the vents.

Measurement Categories



Warning For use in measurement category I (CAT I) only. Do not use in measurement category II/III/IV. Use this device to connect signals or make measurements.

Measurement categories Note

Measurement categories I (CAT I) means that measurements are made on a circuit that is not directly connected to the main power supply. For example, a circuit that is not exported from the main power supply, especially a circuit that is exported from a protected (internal) primary power supply, is measured. In the latter case, the instantaneous stress will change. Therefore, the user should be aware of the instantaneous affordability of the device.

Measurement categories II (CAT II) means that measurements are made on a circuit that is directly connected to a low-voltage device. For example, a measurement on household appliances, portable tools and similar equipment.

Measurement categories III (CAT III) means that measurements are made in construction equipment. For example, a measurement on the distribution boards, circuit breakers, wiring (including cables, Busbars, junction boxes, switches, sockets) in fixed equipment and equipment for industrial use and certain other equipment (for example, fixed motors that are permanently connected to fixtures).

Measurement categories IV (CAT IV) means that measurements are made on the source of low-voltage equipment. For example, a measurement on a meter, a major overcurrent protection device, and a pulse control unit.

Environment

Temperature	
Operating	0°C ~ 55°C
Storage	-40°C ~ 85°C
Humidity	
Operating	5%RH ~ 95%RH, no condensation
Storage	5%RH ~ 95%RH, no condensation
Pollution degree	2
Highest elevation	2000 m

Pollution degree description

Pollution degree 1: No pollution, or only dry non-conductive pollution. This pollution degree has no effect. For example: a clean room or an air-conditioned office environment.

Pollution degree 2: Generally only dry non-conductive pollution occurs. Temporary conduction can sometimes occur due to condensation. For example: General indoor environment.

Pollution degree 3: Conductive pollution occurs, or dry non-conductive pollution becomes conductive due to condensation. For example, an outdoor sheltered environment.

Pollution degree 4: Permanent conductive pollution caused by conductive dust, rain, or snow. For example: Outdoor places.

Recycle precautions



Warning Some of the substances contained in this product may be harmful to the environment or human health. In order to avoid releasing harmful substances into the environment or endangering human health, it is recommended that appropriate methods be used to recover this product to ensure that most materials can be properly reused or recycled. For information about processing or recycling, please contact your local professional organizations.

CONTENT

SAFETY REQUIREMENTS	2
MEASUREMENT CATEGORIES	3
ENVIRONMENT	4
1. GETTING STARTED	7
1.1. PRODUCT INTRODUCTION	7
1.2. FUNCTION DIAGRAM.....	8
1.3. PRODUCT SPECIFICATIONS	8
1.4. PRODUCT UNPACKING.....	11
<i>Precautions</i>	11
<i>Check the packing list</i>	12
2. INSTALLATION	13
2.1. CONNECTOR SIGNAL PINS DISTRIBUTION	13
2.2. USB CABLE REINFORCEMENT DESIGN	15
2.3. DRIVER INSTALLATION	15
3. ANALOG INPUT (AI)	18
3.1. CIRCUIT DIAGRAM	18
3.2. SIGNAL CONNECTION METHODS.....	18
3.3. FLOATING GROUNDED SIGNAL SOURCE	19
<i>Using differential mode (DIFF) connection</i>	19
<i>Non-grounded reference single-ended mode (NRSE) connection</i>	21
3.4. GROUNDED SIGNAL SOURCE	22
<i>Use a differential mode (DIFF) connection</i>	22
<i>Use a non-grounded reference single-ended mode (NRSE) connection</i>	23
3.5. SIGNAL ACQUISITION MODE	24
<i>Hardware timing</i>	24
<i>Continuous acquisition mode</i>	24
<i>Limited number acquisition mode</i>	25
3.6. COMPREHENSIVE SAMPLING RATE AND SINGLE CHANNEL SAMPLING RATE	25
3.7. AI SAMPLING CLOCK	25
3.8. TRIGGER.....	26
<i>Clear trigger</i>	27
<i>Pre-trigger</i>	27
4. DIGITAL INPUT (DI)	28
4.1. SIGNAL ACQUISITION MODE	28
<i>Hardware timing</i>	28
<i>Continuous acquisition mode</i>	28
<i>Limited number acquisition mode</i>	29
4.2. SAMPLING RATE.....	29

4.3.	DI SAMPLING CLOCK	29
4.4.	TRIGGER	30
	<i>Clear Trigger</i>	31
	<i>Pre-Trigger</i>	31
5.	DIGITAL OUTPUT (DO).....	32
5.1.	SIGNAL OUTPUT MODE.....	32
	<i>Immediate output</i>	32
	<i>Hardware timing</i>	32
	<i>Finite number output mode</i>	32
	<i>Infinite loop output mode</i>	33
	<i>Infinite non-loop output mode</i>	33
5.2.	OUTPUT UPDATE RATE	33
5.3.	DO SAMPLING CLOCK.....	34
5.4.	TRIGGER	34
	<i>Clear trigger</i>	35
6.	SYNCHRONIZATION SYSTEM.....	36
6.1.	SAMPLING CLOCK.....	36
6.2.	EXTERNAL TRIGGER.....	36
7.	SERVICE AND WARRANTY	38
8.	ORDERING INFORMATION	39

1. Getting Started

This chapter describes the basic functions of USB-3200 Series Data Acquisition device, as well as product specifications and precautions in the process of product unpacking.

1.1. Product introduction

USB-3200 Series data acquisition device is the multifunctional data acquisition device based on high-speed USB2.0 interface. When connected to the computer, it can be used for continuous high-speed signal acquisition and high-speed control signal output.

USB-3200 series of data acquisition devices can measure analog and digital signals continuously and save the data to the computer hard drive without interruption. It can also provide digital signal output, periodic repetitive signal output, and high-speed uninterrupted non-repetitive signal output controlled by a computer.

USB-3200 series data acquisition device supports operating in Windows OS, providing standard DLLs and support for mainstream development languages including VC++, VB, C#, LabVIEW, and MATLAB.

USB-3200 series data acquisition device provides multiple models, in terms of function and performance. For detailed reference, please turn to Chapter 1.3 for specification description of each model.

Key Features

- High speed USB interface, Plug and Play, USB powered
- 16-bit analog input resolution, support continuous uninterrupted acquisition
- Up to 1MS/s sampling rate for analog input
- Multi-range and separate range support on all analog input channels
- Support single-ended or differential signals on all analog input channels
- Up to 10MS/s/Ch sampling rate for digital I/O

1.2. Function diagram

Figure 1.1 shows the schematic diagram of USB-3200 series data acquisition device.

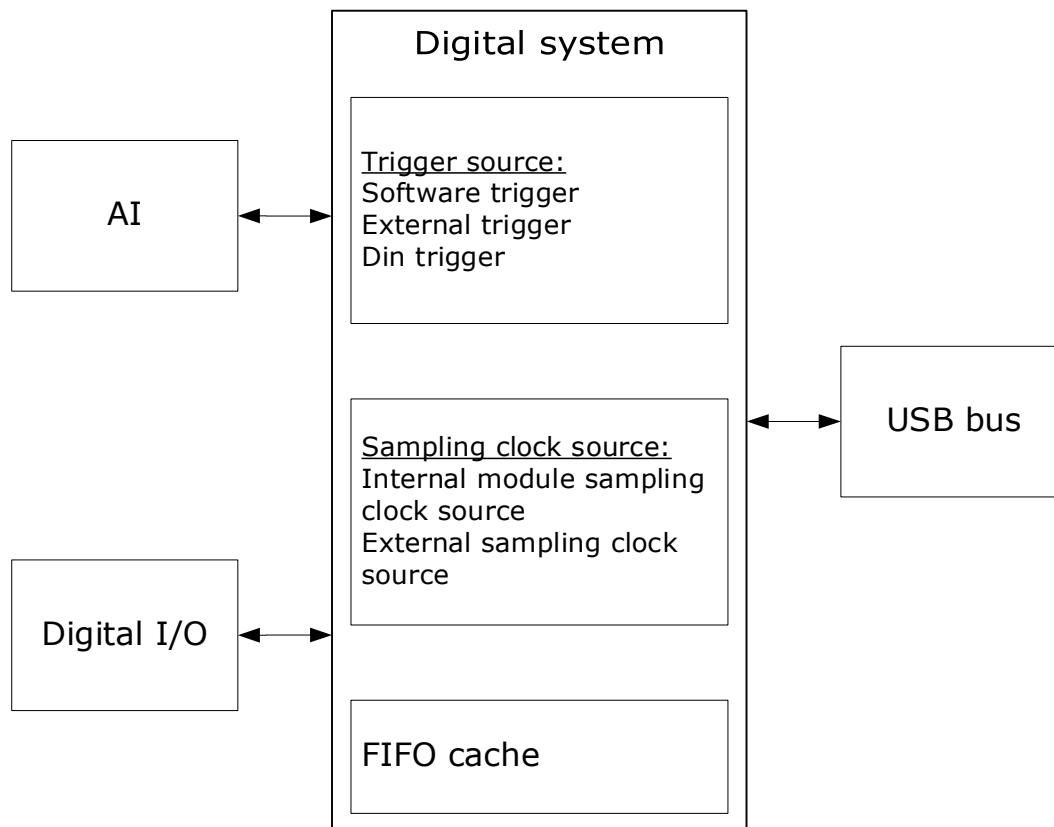

Figure 1.1 USB-3200 series data acquisition device functions

1.3. Product specifications

The following product specification parameters, unless otherwise stated, are acquired at the temperature of 25°C and the humidity of 40%, while the device is turned on for 20 minutes.

Analog input

Number of channels	USB-3230/3231/3232/3233: 24 Single-Ended /12 Difference USB-3220/3221/3222/3223: 16 Single-Ended / 8 Difference USB-3210/3211/3212/3213: 8 Single-Ended / 4 Difference
ADC type	SAR
Resolution	16-bit
Highest sampling rate	USB-3213/3223/3233: 1MS/s, continuous, all channels USB-3212/3222/3232: 500Ks/s, continuous, all channels USB-3211/3221/3231: 250Ks/s, continuous, all channels

	USB-3210/3220/3230: 125KS/s, continuous, all channels
Timing resolution	10ns
Channel synchronization	No
Range	$\pm 10.24\text{ V}/\pm 5.12\text{ V}/\pm 2.56\text{ V}/\pm 1.28\text{ V}/\pm 0.64\text{ V}$
Input coupling mode	DC
Input impedance	500 M Ω
Small signal bandwidth (-3db)	450KHz
Input bias current	0.7nA
Analog input max voltage	The ground voltage of each input side does not exceed $\pm 12\text{ V}$
Software FIFO	2 MPts/Ch
Pre-trigger FIFO	4096 Pts
AI capture mode	Continuous acquisition mode and limited number acquisition mode

Analog input accuracy (with temperature coefficient of 5 ppm/ $^{\circ}\text{C}$)

Range	Gain error (ppm of reading)	Offset error (ppm of range)	Random noise (μVrms)	Full range absolute accuracy (μV)
$\pm 10.24\text{ V}$	20	10	195	820
$\pm 5.12\text{ V}$	50	15	110	550
$\pm 2.56\text{ V}$	55	30	70	315
$\pm 1.28\text{ V}$	100	60	60	220
$\pm 0.64\text{ V}$	200	120	50	100

Digital I/O

Number of channels	4 input, 4 output
Ground reference	DGND
Digital input pull-up resistance	10K Ω
Digital input voltage	High level: 1.95 V ~ 5 V Low level: 0 V ~ 1.2 V
Digital output voltage	High level: 3.3 V Low level: 0 v ~ 0.003 V
Digital output power-on status	Low level

DIN highest sampling rate	10 MS/s/Ch
DOUT highest update rate	10 MS/s/Ch
Timing resolution	10ns
Channel synchronization	Yes
DIN software FIFO	2MPts/Ch
DIN pre-trigger FIFO	2048Pts/Ch
DOUT hardware FIFO	2048Pts/Ch
DIN capture mode	Continuous acquisition mode and OneShot mode
DOUT output mode	Direct output; onboard FIFO waveform periodic generation; onboard FIFO waveform trigger N loop; Uninterrupted non-repetitive signals for computer caches
DOUT edge time	Ascending edge: 6ns Descending edge: 8ns

External trigger

Number of channels	1 input, 1 output
Input voltage	High level: 1.95 V ~ 5 V Low level: 0 V ~ 1.2 V
Output voltage	High level: 3.3 V Low level: 0 v ~ 0.003 V
Output power-on status	Low level
Output edge time	Ascending edge: 6ns Descending edge: 8ns

External sampling clock I/O

Number of channels	1 input, 1 output
Input voltage	High level: 1.95 V ~ 5 V Low level: 0 V ~ 1.2 V
Output voltage	High level: 3.3 V Low level: 0 v ~ 0.003 V
Output power-on status	Low level
Output frequency range	DC ~ 1 MHz
Output edge time	Ascending edge: 6ns Descending edge: 8ns

Calibration

Recommended warm-up time	No less than 20Minutes
Recommended calibration interval	1 year

Bus interface

USB	USB2.0 High Speed interface
-----	-----------------------------

Power supply requirements

USB interface power supply	4.5 V ~ 5.5 V
Typical current without load	400mA
Maximum Load	600mA

Physical properties

Size (mm)	Without connectors: 150*96*28 Connectors included: 150*112*28
Weight (g)	Without connectors: about 185g Connectors included: about 230g
I/O connectors	Bolt terminals
Bolt terminal connection	16 AWG ~ 28 AWG
USB connectors	USB Type B

1.4. Product unpacking

Precautions

To prevent electrostatic discharge (ESD) from damaging the device, please note the following:

- Please wear a grounding wristband or touch a grounded object first to ensure being grounded.
- Before removing the equipment from the packaging, please first connect the anti-static packaging to the grounded object.
- Do not touch the exposed pins of the connector.

- Place your device in anti-static packaging when you are not using the device.

Check the packing list

After unpacking the product, follow the packing list in the box, check the host and each attachment individually to ensure that the items in the box are consistent with the packing list.

If you find that any item is missing, please get in touch with us for help as soon as possible.

If you find that the product comes in damaged after unpacking, please get in touch with us as soon as possible. Do not install damaged equipment on your devices.

2. Installation

This chapter describes signal connection and drive installation of USB-3200 series data acquisition device.

2.1. Connector signal pins distribution

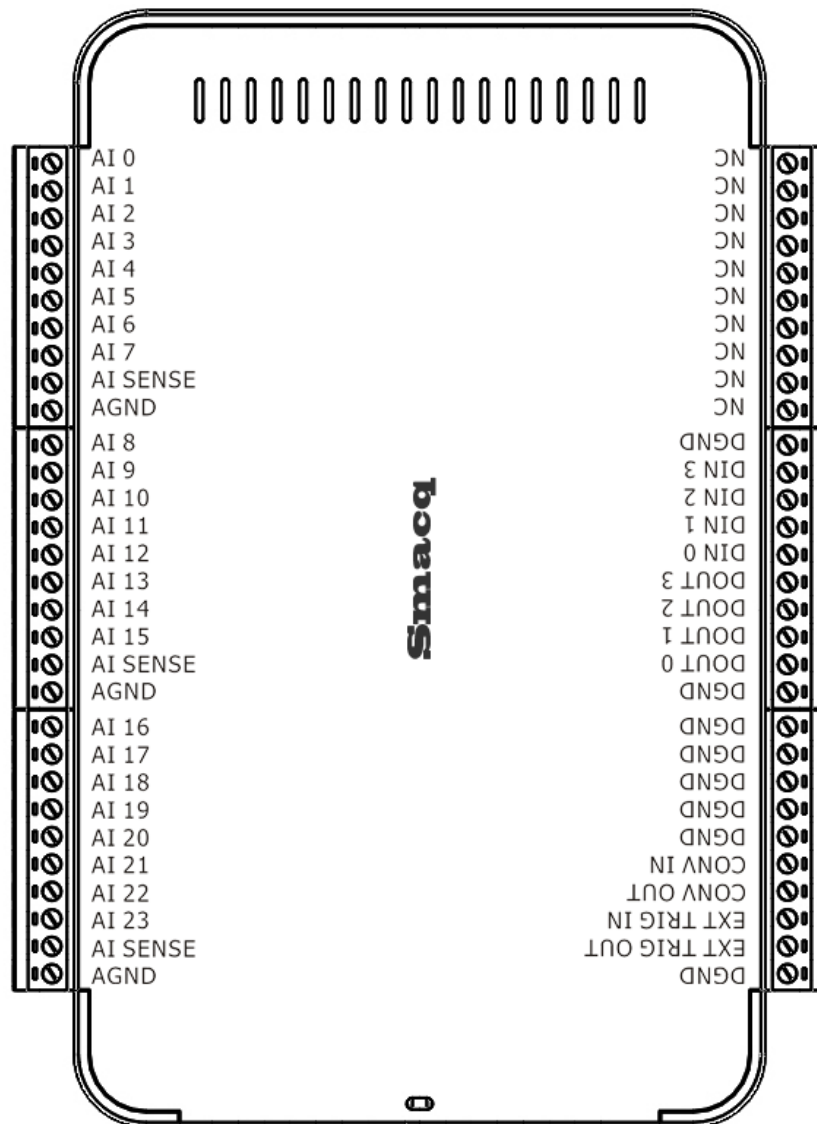

Figure 2.1 USB-3200 signal pins distribution



Attention When USB 3200 DAQ card is connected with a single-ended connector via analog input, AI SENSE should only be connected to the terminal of the group in which the channel is located, that is, the positive and negative ends of the measured analog signal should be connected to the

same terminal, otherwise it will cause a measurement error.

Table 2.1, Signal pin allocation

Signal name	Single-ended input	Differential input
AI 0	Analog input 0	Analog input 0 Cathode
AI 1	Analog input 1	Analog input 0 Negative
AI 2	Analog input 2	Analog input 2 Cathode
AI 3	Analog input 3	Analog input 2 Negative
AI 4	Analog input 4	Analog input 4 Cathode
AI 5	Analog input 5	Analog input 4 Negative
AI 6	Analog input 6	Analog input 6 Cathode
AI 7	Analog input 7	Analog input 6 Negative
AI 8	Analog input 8	Analog input 8 Cathode
AI 9	Analog input 9	Analog input 8 Negative
AI 10	Analog input 10	Analog input 10 Cathode
AI 11	Analog input 11	Analog input 10 Negative
AI 12	Analog input 12	Analog input 12 Cathode
AI 13	Analog input 13	Analog input 12 Negative
AI 14	Analog input 14	Analog input 14 Cathode
AI 15	Analog input 15	Analog input 14 Negative
AI 16	Analog input 16	Analog input 16 Cathode
AI 17	Analog input 17	Analog input 16 Negative
AI 18	Analog input 18	Analog input 18 Cathode
AI 19	Analog input 19	Analog input 18 Negative
AI 20	Analog input 20	Analog input 20 Cathode
AI 21	Analog input 21	Analog input 20 Negative
AI 22	Analog input 22	Analog input 22 Cathode
AI 23	Analog input 23	Analog input 22 Negative
AI SENSE	Analog input reference	Not defined
AGND	Simulated ground	Simulated ground
DI 0	Digital input 0	Not available
DI 1	Digital input 1	Not available
DI 2	Digital input 2	Not available
DI 3	Digital input 3	Not available
DO 0	Digital output 0	Not available
DO 1	Digital output 1	Not available
DO 2	Digital output 2	Not available

Signal name	Single-ended input	Differential input
DO 3	Digital output 3	Not available
DGND	Digital ground	Not available
EXT TRIG out	Trigger signal output	Not available
EXT TRIG in	External trigger signal input	Not available
CONV out	Sampling clock output	Not available
CONV in	External sampling clock input	Not available
NC	Not connected	Not connected

2.2. USB cable reinforcement design

USB cable connectors are prone to be pulled off during operation. USB-3200 series data acquisition devices provide a cable reinforcement design, with which a strap can be used to fix the USB cable to the device to prevent the accidents. Check Figure 2.2 for details.

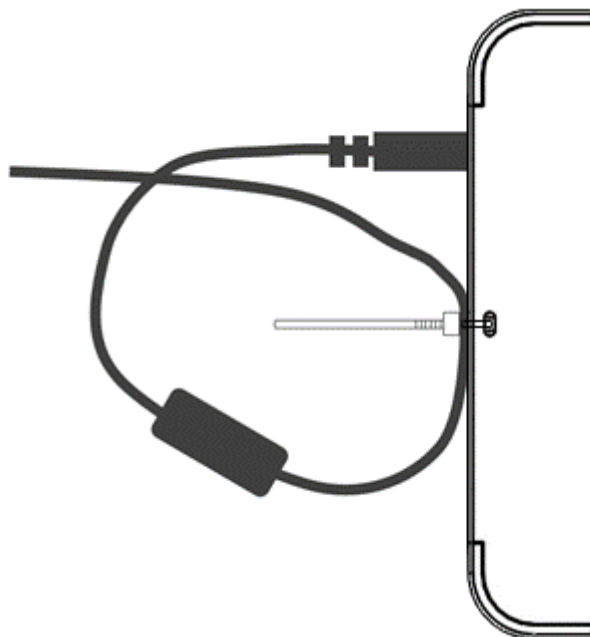



Figure 2.2 USB cable reinforcement design

2.3. Driver installation

Smacq USB-3200 series data acquisition device support Microsoft Windows XP, Windows 7, Windows 8/8.1, and Windows 10, including all the 32-bit and 64-bit versions. To install the driver for USB-3200 devices, you need to turn off driver signature enforcement first.

Here is an example step-by-step tutorial on how to install the driver in Windows 7.

- 1) Connect your USB-3200 card to the computer and launch the Device Manager in Windows.
- 2) There should be a device with an exclamation point.”  Smacq USB Series DAQ
Right-click it, select “Update driver”.
- 3) In the pop-up dialog box, select “Browse my computer for driver software”
- 4) And then select “Let me pick from a list of device drivers on my computer”
- 5) Click on “Next” and then select “Have disk”
- 6) Click Browse in the pop-up dialog box, then enter the \USB-3000SeriesDAQ\driver folder in the CD-ROM, then enter the "win7" folder, then the 32-bit operating system enters the "x86" folder, the 64-bit operating system enters the "x64" folder, select the "sub.inf" file, and then click "Open". (The drivers of Windows8/8.1 and Windows10 are the same as those of Windows7, using the same file.)
- 7) Then in the dialogue of “Install from disk”, click on “Yes”.
- 8) Click “Next”, if the Windows security warning pops up, you need to select “Install this driver software anyway” to finish the installation.

After these steps, the operating system will start installing the driver, which usually takes about 30 seconds. After the driver is installed, the exclamation point in Device Manager will disappear, as shown in the following Figure 2.3.

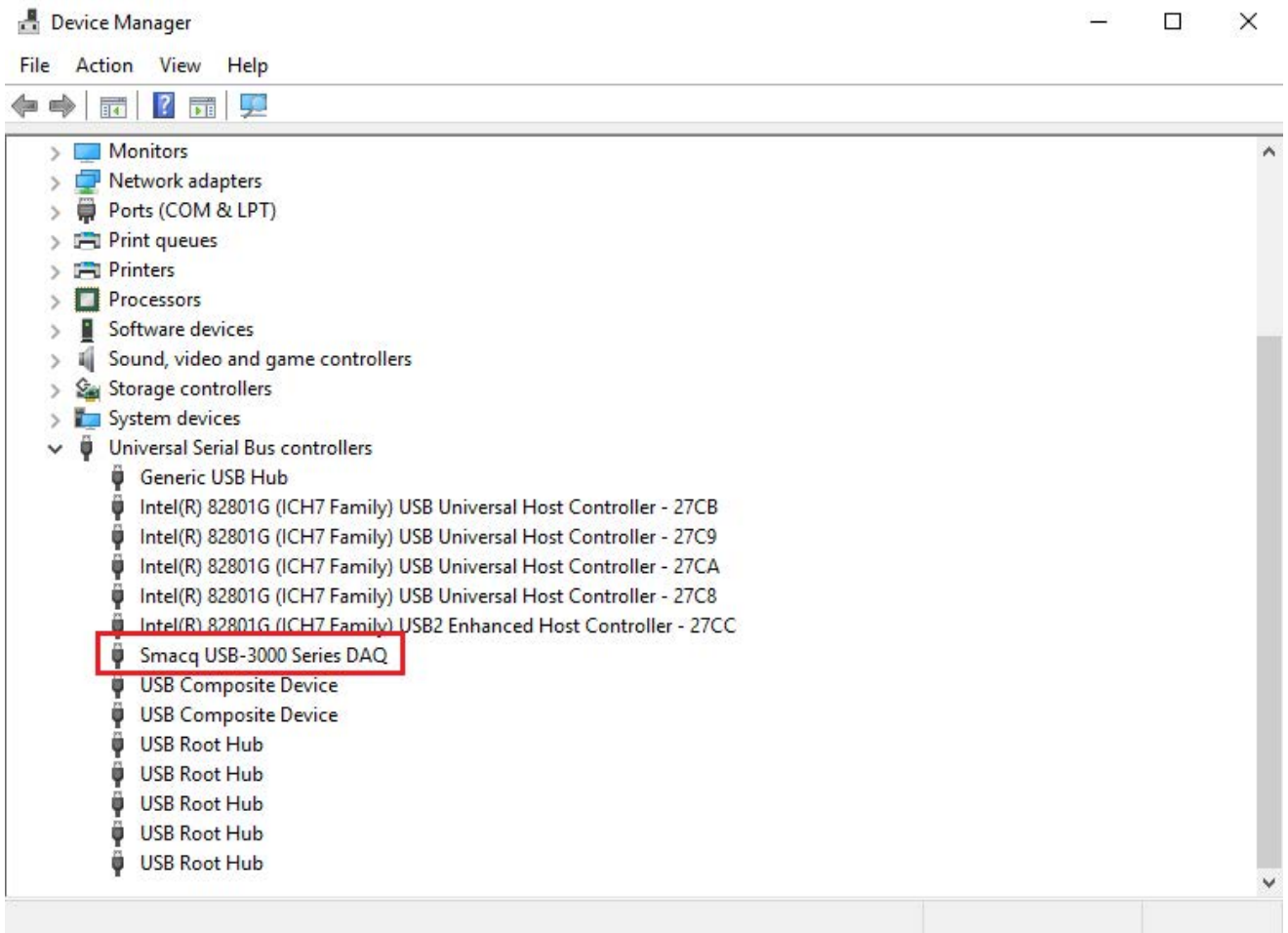

Figure 2.3 the Device Manager after the driver is correctly installed

3. Analog Input (AI)

This chapter describes measuring the relevant content of analog input signals on USB-3200 series data acquisition devices. AI here is short for Analog Input.

3.1. Circuit diagram

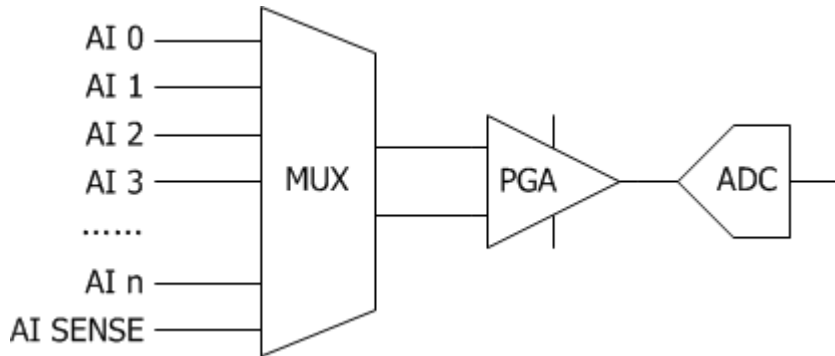

Figure 3.1 analog input circuit

3.2. Signal connection methods

USB-3200 series data acquisition devices support analog input acquisition connection methods of non-grounding reference single-ended input (NRSE) and differential input (DIFF).

Table 3.1 lists the recommended connection methods for floating-ground signal sources and grounding signal sources

Analog input mode	Floating ground signal source (not connected to GND of the building)	Grounded signal source
Example	<ul style="list-style-type: none"> ● Ungrounded thermocouples ● Signals that are isolated ● Battery-powered devices 	<ul style="list-style-type: none"> ● Signals that are not isolated
Differential input (DIFF)		

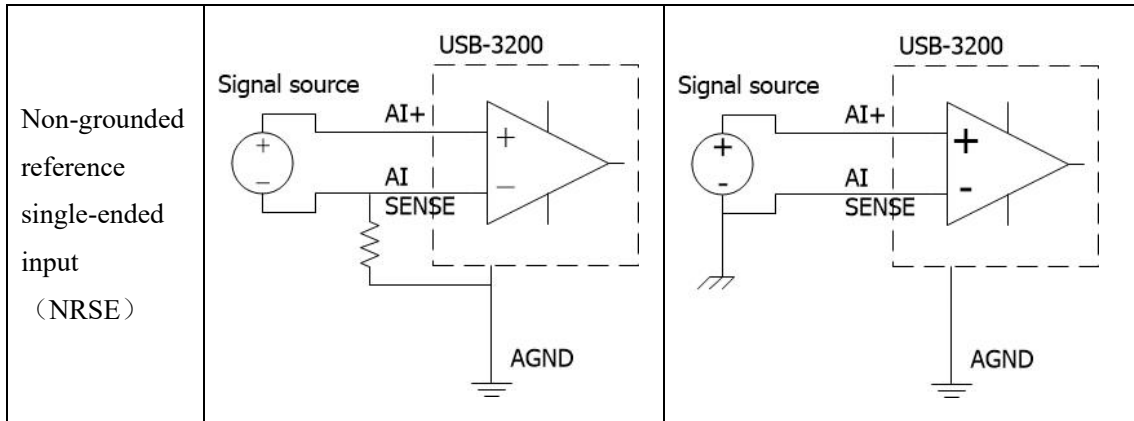

3.3. Floating grounded signal source

A floating grounded signal source is not connected in any way to the building ground system but, it has an isolated ground-reference point. Common floating grounded signal sources are transformers, thermocouples, battery equipment, optical isolators, and isolation amplifier output. An instrument or device with isolated output is a floating-ground signal source.



Attention When measuring the floating ground signal source, it is important to connect the negative end of the signal source directly or indirectly through the resistor to the AGND.

Using differential mode (DIFF) connection

When any of the following conditions are true, a differential mode should be used to connect the floating signal:

- Analog input AI+ and AI- are all valid signals.
- Low input signal voltage while higher accuracy demanded
- The cable length of the connection signal to the acquisition device exceeds 3 meters
- The input signal requires a separate ground-reference point or a return signal
- There is obvious noise in the environment of the connection wire

Differential connection mode can reduce noise interference and improve the common-mode suppression ability of acquisition device.

For a floating signal source with less than 100ΩF internal resistance, you can directly connect the negative end of the signal to AI- and AI-GND ports and connect the positive end of the signal to AI+ ports, as shown below in figure 3.2.

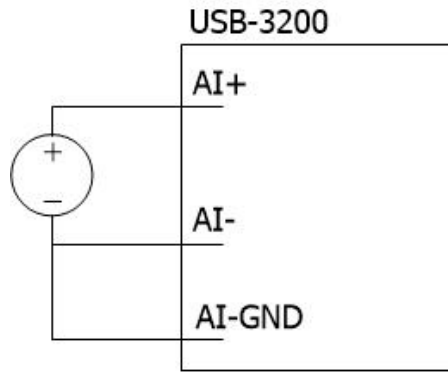

The internal resistance is less than 100Ω

Figure 3.2 differential input mode for direct connection

However, for a floating signal source with large internal resistance, the above connection will lead to the imbalance of differential signal, and the common-mode noise will be coupled to the signal of AI+ while not to AI-, so that the common-mode noise will appear in the measured results. Therefore, for such a signal source, you can use a bias resistor approximately 100 times the internal resistance of the signal source to connect to AI- and AI-GND ports, as shown in Figure 3.3. This can make the differential signal close to equilibrium, hence couple the same amount of noise at both ends of the signal to enable better common-mode noise suppression.

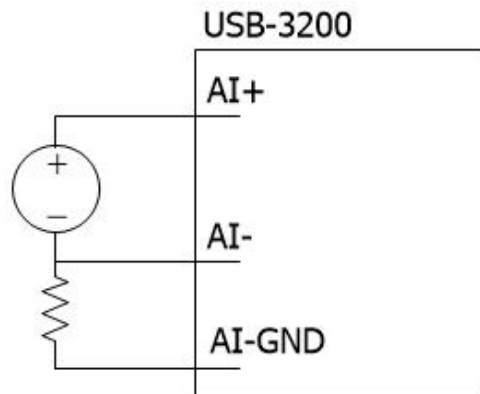

$R \approx 100 \times$ Internal resistance of signal source

Figure 3.3 differential input mode with single bias resistor

For a floating signal source with a large internal resistance, you can use the differential input mode with two bias resistors, as shown in Figure 3.3. The fully balanced bias resistor connection in this way can provide a slightly better noise suppression, but it can reduce the load on the signal source and result in gain errors. For example, suppose the internal resistance of the signal source is $2k\Omega$, and two equilibrium resistors are $100k\Omega$ each, then the signal source load is $200k\Omega$, which results in a 1% gain error.

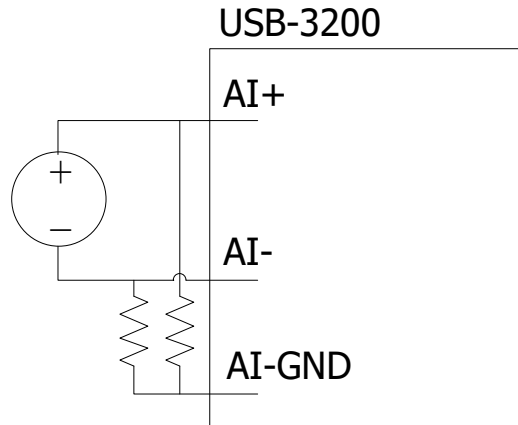

Figure 3.4 balanced bias resistor differential input mode

For AC-coupled floating signal sources, a resistor is required to provide DC loops for the positive input of instrument amplifier, AI+, as shown in Figure 3.5.

If the AC coupled float signal source has a smaller internal resistance, the AI+ and AI-GND connection resistance values should be generally set as 100k Ω to 1M Ω . Hence, it does not aggravate the load of the signal source, nor does it generate an offset voltage due to the bias current of the instrument amplifier. In this case, you can directly connect AI- and AI-GND.

If the internal resistance of the AC coupled floating source signal is large, the differential input mode utilizing the equilibrium bias resistor described earlier should be used, and it is important to note the gain error that may be caused by the equilibrium bias resistor.

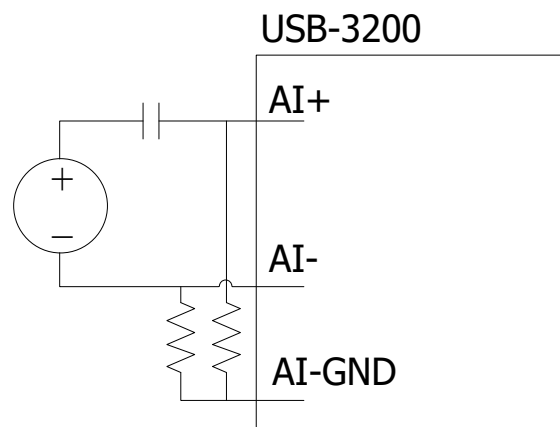

Figure 3.5 Differential input method for AC coupled floating signal source

Non-grounded reference single-ended mode (NRSE) connection

When both the following conditions are true, you can connect the float signal using a non-grounded reference single-end mode:

- The input signal voltage is higher than 1V

- The length of the cable connecting signals to the acquisition device is lower than 3 meters

If the signal does not meet the above conditions, it is recommended to use a differential mode connection to ensure better signal integrity. In single-ended mode, the electrostatic noise and electromagnetic noise of the coupled input signal connection are more than that in differential mode.

Non-grounded reference single-ended mode (NRSE) connection methods are shown in Figure 3.6. Note that the resistance value setting of the grounded resistance is consistent with the that in difference mode.

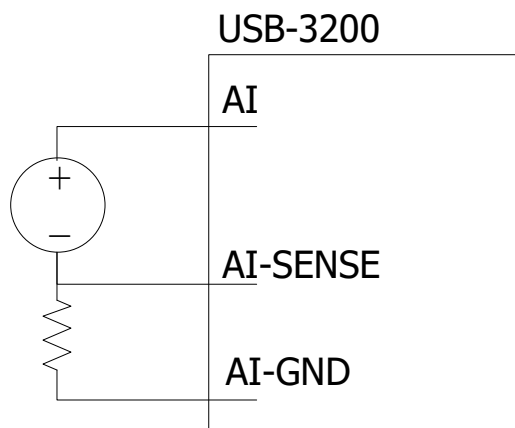

Figure 3.6 floating-grounded signal source NRSE input

3.4. Grounded signal source

The grounded signal source is a signal source connected to the building ground. If the computer is connected to the same power supply as the signal source, the source is already connected to a common ground point relative to the device. Instruments and equipment connected to the building power supply system while with non-isolated outputs belong to this type of signal source.

The potential difference between devices connected to the power supply system of the same building is usually 1mV to 100mV, but the potential difference may be larger if the distribution line is not properly connected. If the measurement method is improper, the potential difference may cause measurement errors. Follow the connection guide for the grounded signal source below to reduce the grounded potential difference of the measured signal.

Use a differential mode (DIFF) connection

Differential mode connection should be used when any of the following conditions is true:

- All analog input channels are connected with valid signal.
- Low input signal voltage while high accuracy demanded

- The cable connecting the signal to the acquisition device exceeds 3 meters
- The input signal requires a separate reference location or a return signal
- There is obvious noise in the environment of the signal wire

Differential connection mode can reduce noise interference and improve the common-mode suppression of the acquisition device. Differential connection allows the input signal to float within the common-mode operating range of the instrument amplifier.

Figure 3.7 shows how to use differential mode to connect the grounded signal source

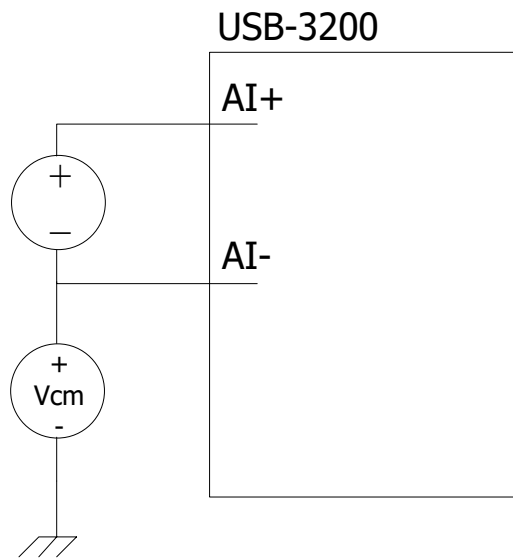

Figure 3.7 grounded signal source DIFF input

Use a non-grounded reference single-ended mode (NRSE) connection

When all of the following conditions are true, you can connect the float signal using a non-grounded reference single-ended mode:

- The input signal voltage is higher than 1V
- The cable connecting the signal to the acquisition device is less than 3 meters long
- The input signal shares a reference point whose voltage is not AI-GND.

If the signal does not meet the above conditions, it is recommended to use a differential mode connection to ensure better signal integrity. In single-ended mode, the electrostatic noise and electromagnetic noise of the coupled input signal connection are more than that in the difference mode.

Figure 3.8 shows the grounded signal source (NRSE) connection in non-grounded reference single-ended mode.

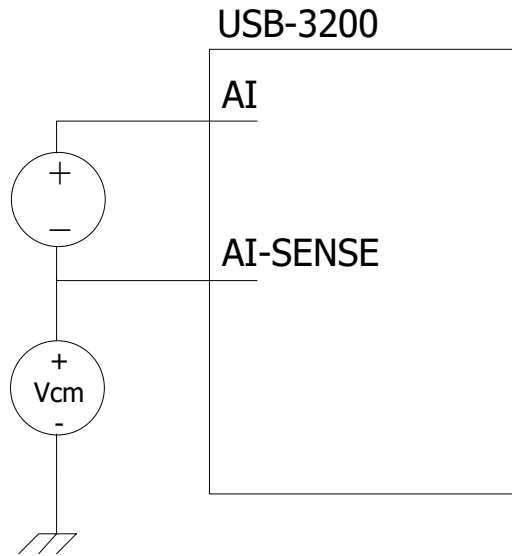

Figure 3.8 grounded signal source NRSE input

3.5. Signal acquisition mode

When the USB-3200 series data acquisition device performs analog input measurement, it supports continuous acquisition mode or limited number acquisition mode. The sampling rates of both modes are hardware-timed. The limited number acquisition mode is called OneShot mode.

Hardware timing

Hardware timing means that the sampling rate of AI acquisition is controlled by a hardware digital signal (AI sampling clock), which can be generated internally or externally.

Please refer to the chapter of “Synchronization system” for detailed settings for using externally provided sampling clocks.

Continuous acquisition mode

Continuous acquisition mode refers to continuous and uninterrupted collection of data at defined sampling speed.

In continuous acquisition mode, after the AI acquisition is triggered, the acquisition device collects the signal at a fixed sampling speed, buffers data into FIFO, and continuously uploads the data in the FIFO to the computer memory buffer. The user program only needs to continuously process the data in memory to achieve continuous uninterrupted data acquisition.

If the user program does not process the data fast enough, the data will gradually fill the 2M points of storage space in computer memory buffer. New data cannot be written correctly after the

memory is filled up, resulting in discontinuous data.

Limited number acquisition mode

Limited number acquisition mode (OneShot mode) refers to one-time acquisition to get the set number of collection points at the set sampling speed.

In OneShot mode, after the AI acquisition triggers, the acquisition device automatically starts the acquisition and stops it after the acquisition reaches the set number of times on the set sampling speed. The user program only needs to read the set data amount from the computer memory buffer.



Attention The set number of collection points cannot exceed 2MPts.

3.6. Comprehensive sampling rate and single channel sampling rate

When the USB-3200 series data acquisition device is used for single channel acquisition, the channel can achieve the maximum sampling rate.

If two channels are enabled for one acquisition, the sample rate for each channel is half the set sample rate; if three channels are enabled, the sample rate for each channel is one third of the set sample rate. When you have more channels, the calculation method is like this.

3.7. AI sampling clock

The USB-3200 series data acquisition device has a rich collection timing option. The schematic diagram of the AI sampling clock is shown in Figure 3.9.

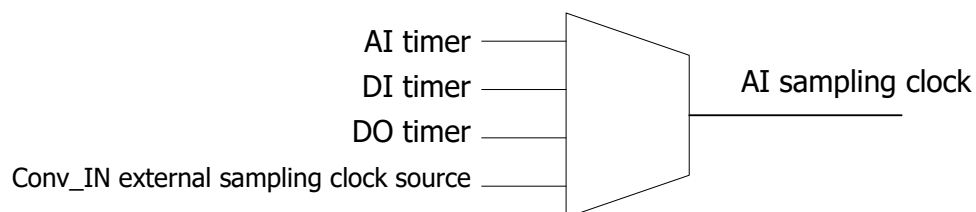

Figure 3.9 AI sampling clock options

The AI acquisition uses the AI timer signal as the AI sampling clock by default. The AI acquisition can be set via software to use other sampling clock sources to achieve the synchronization of each function.

All timers can be set in steps of 10ns, but the set sampling rate cannot exceed the maximum sampling rate supported by the device.

The external sampling clock source input from Conv_IN cannot be set to divide or multiply. It can only be used directly as the sampling clock. The AI timer output signal can be set to the Conv_OUT pin via software for simultaneous synchronization of multiple devices. See the "Synchronization System" chapter for details on the external clock.

3.8. Trigger

The USB-3200 series data acquisition device provides rich trigger options. The schematic diagram of the AI acquisition trigger options are shown in Figure 3.10.

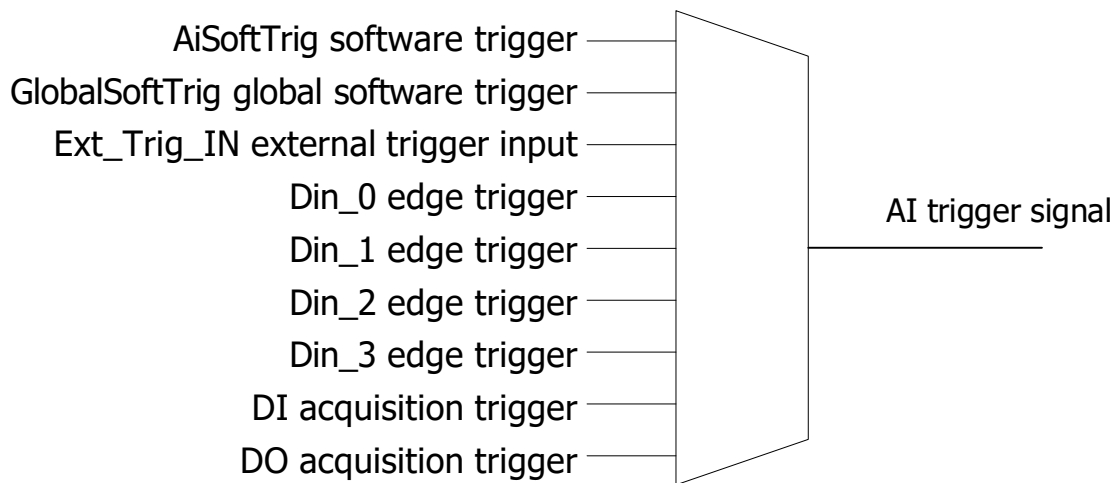

Figure 3.10 AI trigger options

The AI acquisition uses the AiSoftTrig software trigger as the trigger source by default. The AI acquisition can use other trigger sources via software settings to achieve the synchronization of each function.

AiSoftTrig software trigger and GlobalSoftTrig global software trigger are software triggers, which are used to send a command to the acquisition device to initiate device triggering.

Ext_Trig_IN external trigger means that when Ext_Trig_IN receives a rising edge, the device triggers. The AI trigger signal can be set to the Ext_Trig_OUT pin via software for multiple device

synchronization. See the "Synchronization System" chapter for details on the external trigger.

The Din_0 ~ Din_3 edge trigger means that when the DIO is configured as an input, the DIO pin receives a rising edge and the device triggers.

DI acquisition trigger and DO acquisition trigger can be used to trigger the AI function alongside their own functions to achieve the synchronization of each function.

Clear trigger

The AI trigger status can be reset to an untriggered state by software settings.

Pre-trigger

The pre-trigger function is used to record the pre-trigger signal. The pre-trigger function relies on the hardware FIFO to store the data of the pre-trigger signal, so the number of pre-triggered points is limited and cannot exceed 4kPts. The pre-trigger function diagram is shown in Figure 3.11.

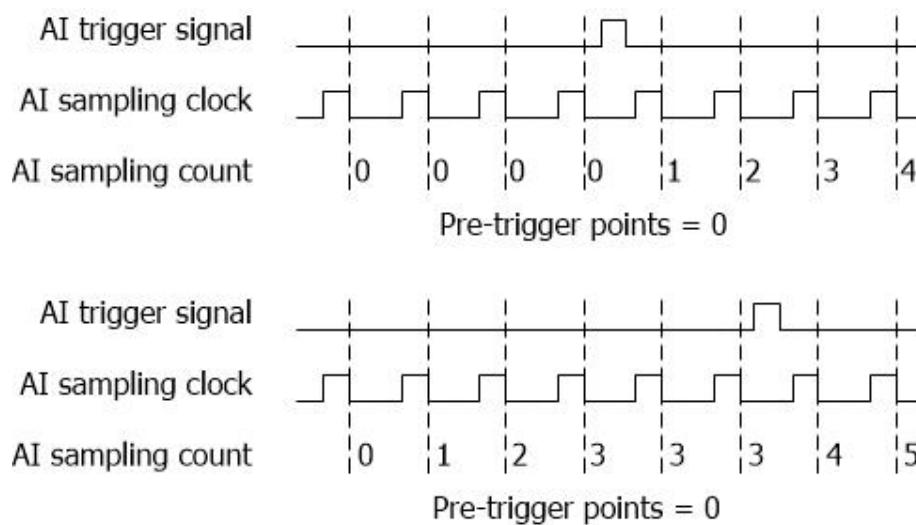

Figure 3.11 AI pre-trigger function

When the pre-trigger point is set to 0, the data before the trigger signal is not stored, and the user will not be able to obtain the signal state before the trigger signal.

When the pre-trigger signal is set to be larger than 0, for example, in Figure 3.11, the number of pre-trigger points is set to 3, then the data before the trigger signal will be stored, and when the stored quantity reaches 3, the newly acquired data will automatically remove the oldest data in the FIFO to ensure that the latest 3 data is saved in the FIFO before the trigger.

4. Digital Input (DI)

This chapter introduces the digital input signal acquisition on USB-3200 series data acquisition devices. DI is the abbreviation of Digital Input here. Figure 4.1 is a schematic diagram of the digital input circuit.

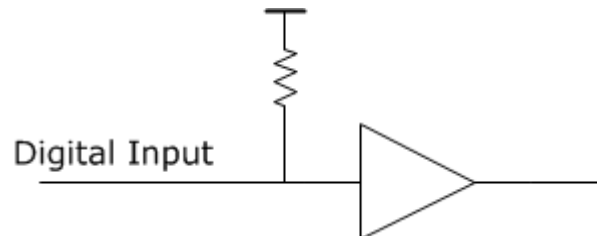

Figure 4.1 digital input circuit Figure

4.1. Signal acquisition mode

When the USB-3200 series data acquisition device performs DI acquisition, it supports continuous acquisition mode or limited number acquisition mode. The sampling rates of both modes are hardware-timed. The limited number acquisition mode is called OneShot mode.

Hardware timing

Hardware timing refers to the sampling rate of the sample acquired by DI. It is controlled by the hardware digital signal (DI sampling clock). This signal can be generated internally or externally.

For details on using an externally supplied sampling clock, refer to the "Synchronization System" chapter.

Continuous acquisition mode

The continuous acquisition mode refers to continuous and uninterrupted data acquisition at a set sampling speed.

In the continuous acquisition mode, after the DI acquisition triggers, the acquisition device collects the signal at a fixed sampling speed, buffers it in the FIFO, and continuously uploads the data in the FIFO to the computer memory buffer. The user program only needs to continuously process the data in memory to achieve continuous uninterrupted data collection.

If the user program could not process the data fast enough, the data will gradually fill up the 2M points of storage space in the computer's memory buffer. After filling it up, the new data cannot be written into memory buffer correctly, resulting in data discontinuity.

Limited number acquisition mode

Limited number of acquisition modes (OneShotmode) refers to one-time acquisition of the set number of collection points at the set sampling speed.

In OneShot mode, after the DI acquisition triggers, the acquisition device will start acquiring set number of data at the set sampling speed and stop the acquisition automatically after. The user program only needs to read the set data amount from the computer memory buffer.



Attention The number of set collection points cannot exceed 2MPts.

4.2. Sampling rate

For USB-3200 series of data acquisition devices, the DI sampling rate is up to 10 Msa/s/ch. This is parallel simultaneous sampling of all channels, with each channel able to achieve this highest sampling rate.

4.3. DI sampling clock

The USB-3200 series data acquisition device has a rich DI acquisition timing option. The DI sampling clock is shown in Figure 4.2.

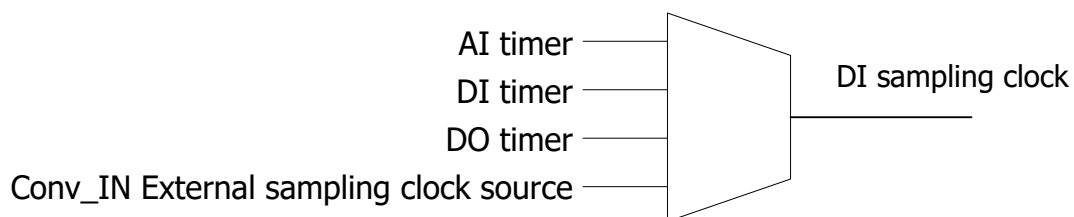

Figure 4.2 DI sampling clock option

The DI acquisition uses the DI timer signal as the DI sampling clock by default. The DI acquisition can be set via software to use other sampling clock sources to achieve the synchronization of each function.

All timers can be set in steps of 10ns, but the set sampling rate cannot exceed the maximum sampling rate supported by the device.

The external sampling clock source input from Conv_IN cannot be set to divide or multiply. It can

only be used directly as the sampling clock. The DI timer output signal can be set to the Conv_OUT pin via software for simultaneous synchronization of multiple devices. See the "Synchronization System" chapter for details on the external clock.

4.4. Trigger

The USB-3200 series data acquisition device provides rich trigger options. The DI acquisition trigger options are shown in Figure 4.3.

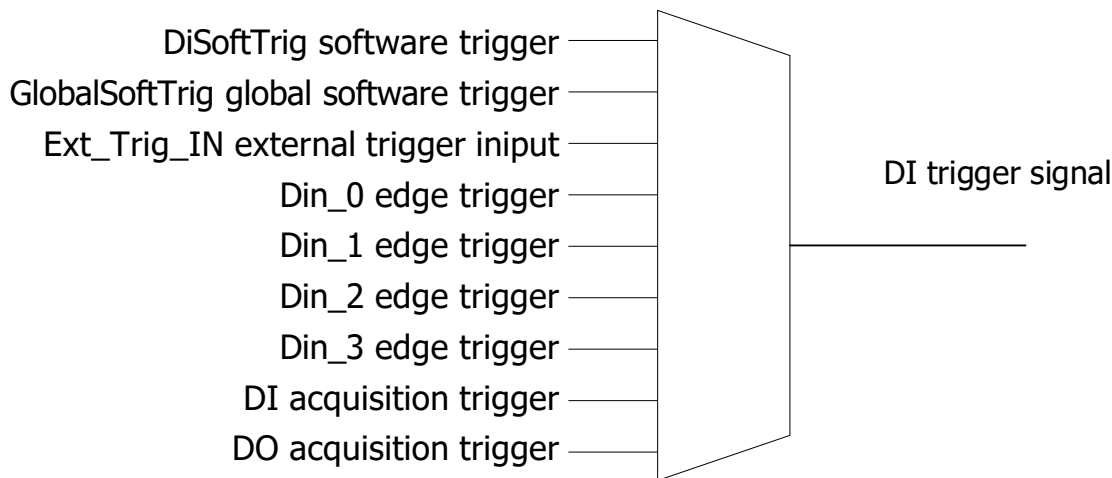

Figure 4.3 DI trigger options

The DI acquisition uses the DiSoftTrig software trigger as the trigger source by default. The DI acquisition can use other trigger sources via software settings to achieve the synchronization of each function.

DiSoftTrig software trigger and GlobalSoftTrig global software trigger are software triggers, which are used to send a command to the acquisition device to initiate device triggering.

Ext_Trig_IN external trigger means that when Ext_Trig_IN receives a rising edge, the device triggers. The AI trigger signal can be set to the Ext_Trig_OUT pin via software for multiple device synchronization. See the "Synchronization System" chapter for details on the external trigger.

The Din_0 ~ Din_3 edge trigger means that when the DIO is configured as an input, the DIO pin receives a rising edge and the device triggers.

DI acquisition trigger and DO acquisition trigger can be used to trigger the DI function alongside their own functions to achieve the synchronization of each function.

Clear Trigger

The DI trigger status can be reset to an untriggered state via software settings.

Pre-Trigger

The pre-trigger function is used to record the pre-trigger signal. The pre-trigger function relies on the hardware FIFO to store the data of the pre-trigger signal, so the number of pre-triggered points is limited and cannot exceed 4kPts. The pre-trigger function diagram is shown in Figure 4.4.

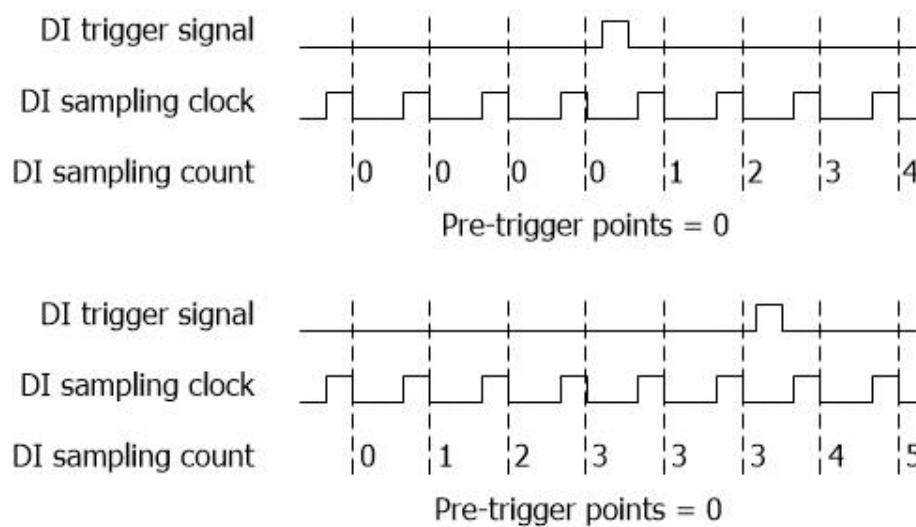

Figure 4.4. DI pre-trigger function

When the pre-trigger point is set to 0, the data before the trigger signal is not stored, and the user will not be able to obtain the signal state before the trigger signal.

When the pre-trigger signal is set to be larger than 0, for example, in Figure 4.4, the number of pre-trigger points is set to 3, then the data before the trigger signal will be stored, and when the stored quantity reaches 3, the newly acquired data will automatically remove the oldest data in the FIFO to ensure that the latest 3 data is saved in the FIFO before the trigger.

5. Digital Output (DO)

This chapter introduces the digital signal output for the USB-3200 series data acquisition device. The digital input is referred to as DO here, the abbreviation of Digital Output. Figure 5.1 is a schematic diagram of the digital output circuit.

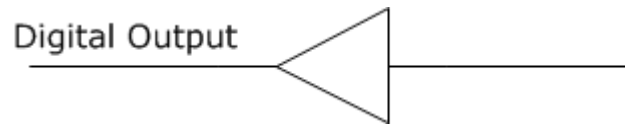

Figure 5.1 Digital output circuit

5.1. Signal output mode

When the USB-3200 series data acquisition device is utilized for digital output, the following four output modes are supported:

- Immediate output
- Finite number output
- Infinite number of loop output
- Infinite non-loop output

Immediate output

Immediate output refers to the output state without buffer and no waveform. The computer sends a command to the acquisition device, and it immediately outputs the specified level state.

Hardware timing

The three output modes mentioned below refer to the mode of outputting digital waveforms, so the sampling rate of the output waveform is an important parameter. When the acquisition device is in DO mode, the DO sampling clock is generated by hardware timing. The sampling clock signal can be generated internally or externally.

For details on using an externally supplied sampling clock, refer to the "Synchronization System" chapter.

Finite number output mode

The limited number of output modes means that the digital waveform data to be output is first stored in the hardware FIFO, then the output sampling rate is set, the number of times the

waveform needs to be output is set, and the channel for outputting the digital waveform is set. After the DO output is triggered, the capture card begins to output a digital waveform in accordance with the set parameters. After the set number of outputs is reached, the capture card stops outputting the digital waveform.



Attention When the specified number of outputs is completed, the DO output level state stays at the level defined by the last point of the waveform data.

Infinite loop output mode

Infinite loop output mode means that the digital waveform data to be output is first stored in the hardware FIFO, and then the output sampling rate is set. After the DO is triggered, the acquisition device starts to output the digital waveform according to the set parameters, and continuously loops the output until the DO triggers cleared to an untriggered state.



Attention After clearing the DO trigger to the untriggered state, the DO output level state stays at the level state at which the DO trigger is cleared.

Infinite non-loop output mode

The infinite non-loop output mode refers to a waveform in which the DO output exceeds the length of the hardware FIFO space, and the computer transfers the data in batches to the DO hardware FIFO.

For example, a waveform with a length of 1M point needs to be output at a sampling rate of 10kSa/s, and the DO hardware FIFO space is only 2k points, so the waveform of 1M point length needs to be transferred to the DO hardware FIFO in 500 times. The 2k point data in the hardware FIFO, with an output sampling rate of 10kSa/s, can be transmitted in 0.2 seconds. Therefore, the computer must start a new data transmission in less than 0.2 seconds to ensure the continuity of DO output waveform.

When the waveform output in the hardware FIFO is complete and no new data arrives, the DO output level state will remain at the level defined by the last point.

5.2. Output update rate

USB-3200 series data acquisition device DO output update rate can reach up to 10MSa/s/Ch. This means parallel simultaneous sampling of all channels, while each channel can achieve this highest sampling rate.

5.3. DO sampling clock

The USB-3200 series data acquisition device has rich DO acquisition timing options. The DO sampling clock is shown in Figure 5.2.

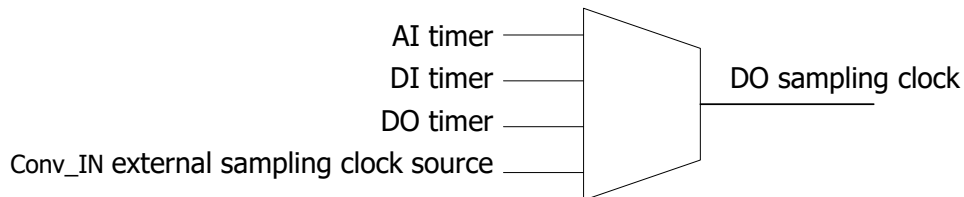

Figure 5.2 DO sampling clock option

The DO acquisition uses the DO timer signal as the DO sampling clock by default. You can set DO acquisition to use other sampling clock sources to achieve the synchronization of each function via software settings.

All timers can be set in steps of 10ns, but the set sampling rate cannot exceed the maximum sample rate supported by the device.

The external sampling clock source input from Conv_IN cannot be set to divide or multiply. It can only be used directly as the sampling clock. The DO timer output signal can be set to the Conv_OUT pin via software for simultaneous synchronization of multiple devices. See the "Synchronization System" chapter for details on the external clock.

5.4. Trigger

The USB-3200 series of data acquisition devices provide a rich set of trigger options, as shown in Figure 5.3, which describes trigger options for the DO output.

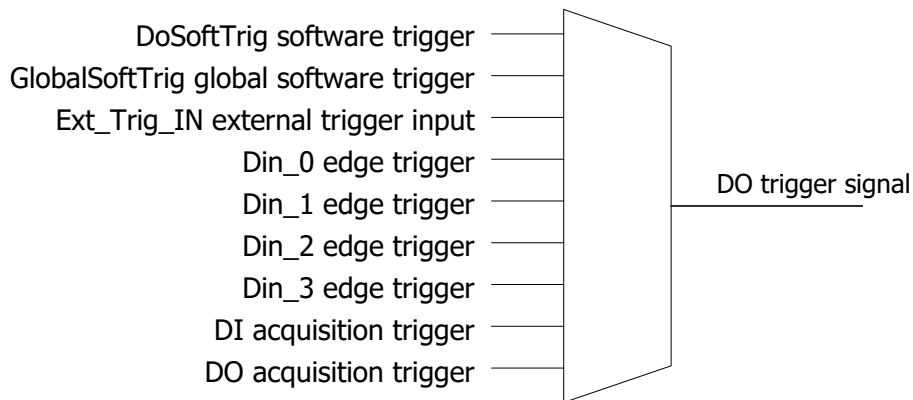

Figure 5.3 DO trigger options

The DO output uses the channel exclusive software trigger signal DoSoftTrig as the trigger source by default. You can set DO output to use other trigger sources to achieve the synchronization of each function via software settings.

The DoSoftTrig software trigger and the GlobalSoftTrig global software trigger are both software triggers, which means the computer sends a command to the data acquisition device to achieve device triggering.

Ext_Trig_IN external trigger means that when Ext_Trig_IN receives a rising edge, the device triggers. The DO trigger signal can be set to the Ext_Trig_OUT pin via software for multiple device synchronization. See the "Synchronization System" chapter for details on external triggering.

The Din_0 ~ Din_3 edge trigger means that when the DIO pin is configured as an input, and the DIO pin receives a rising edge, the device triggers.

DI acquisition trigger and DO acquisition trigger can be used to trigger the DO function alongside their own functions to achieve the synchronization of each function.

Clear trigger

The DO trigger status can be reset to an untriggered state via software settings.

6. Synchronization System

This chapter introduces the multi-card synchronization system of the USB-3200 series data acquisition device. The synchronous system has 4 ports, sampling clock input, sampling clock output, external trigger input, and external trigger output.

6.1. Sampling clock

The sampling clock is used to eliminate the error of the clock between multiple acquisition devices, and achieve the synchronization of the sampling rate between multiple acquisition devices. At this time, the sampling clock output of one of the acquisition devices should be connected to the sampling clock input of other acquisition devices and use the appropriate software settings. Figure 6.1 shows the sampling clock input circuit.

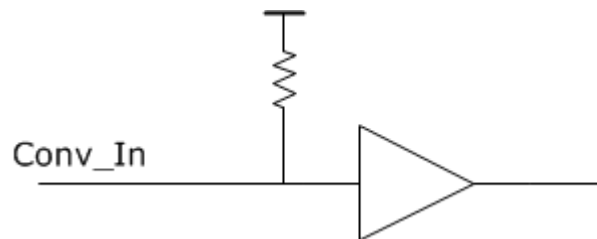

Figure 6.1 sampling clock input circuit

The sampling clock output circuit diagram is shown in Figure 6.2. The following sources can be selected as output options:

- AI sampling clock
- DI sampling clock
- DO sampling clock

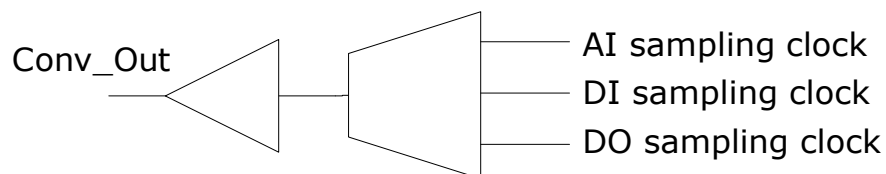

Figure 6.2 Sampling clock output circuit

6.2. External trigger

The pins of external trigger input and output are used to trigger the USB-3200 series acquisition

device in synchronization with an external device.

Each function trigger source of the acquisition device can select the external trigger input pin Ext_Trig_In as the trigger source. The external trigger input circuit diagram is shown in Figure 6.3.

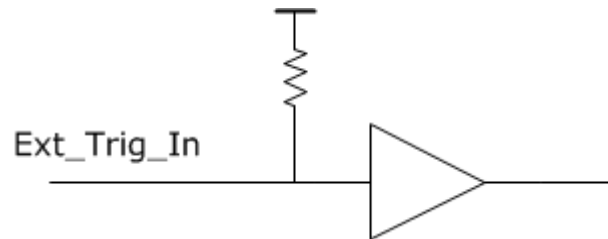

Figure 6.3 External trigger input circuit

When the trigger signal of the specified function is set as the output source, the Ext_Trig_Out pin will output a high level pulse for 1us while the function is triggered.

The circuit diagram of the external trigger output Ext_Trig_Out is shown in Figure 6.4. The following sources can be selected as output options:

- AI acquisition trigger
- DI acquisition trigger
- DO acquisition trigger

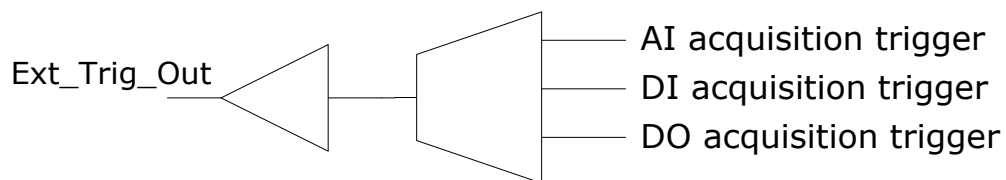

Figure 6.4 External trigger output circuit

7. Service and Warranty

Beijing SMACQ Technology Co., Ltd. is committed to its products during the warranty period, if the product fails under normal use in warranty, we will repair or replace defected parts for free. Please refer to the warranty explanation in the box for detailed instructions.

In addition to the warranties mentioned in this manual and the warranty note, we do not provide any other warranties, express or implied, including, but not limited to, any implied warranties as to the tradable nature of the product and the suitability of the special purpose.

To get more technical support and service details, or if you have any questions about using this product and this document, you are welcome to contact us:

Phone: (+86)10-52482802

E-mail: service@smacq.com

Website: <http://www.smacq.com>

<http://www.smacq.cn>

8. Ordering Information

Host

Model	Notes
USB-3233	24-AI (1 MSa/s), 4-DI, 4-DO
USB-3232	24-AI (500 kSa/s), 4-DI, 4-DO
USB-3231	24-AI (250 kSa/s), 4-DI, 4-DO
USB-3230	24-AI (125 kSa/s), 4-DI, 4-DO
USB-3223	16-AI (1 MSa/s), 4-DI, 4-DO
USB-3222	16-AI (500 kSa/s), 4-DI, 4-DO
USB-3221	16-AI (250 kSa/s), 4-DI, 4-DO
USB-3220	16-AI (125 kSa/s), 4-DI, 4-DO
USB-3213	8-AI (1 MSa/s), 4-DI, 4-DO
USB-3212	8-AI (500 kSa/s), 4-DI, 4-DO
USB-3211	8-AI (250 kSa/s), 4-DI, 4-DO
USB-3210	8-AI (125 kSa/s), 4-DI, 4-DO

Standard accessories

Model	Notes
USB-A-B	USB connection cable, 1.5 meters, USB-A type to USB-B type
TB10-3.81	10-bit, 3.81mm pitch terminal block

Optional accessories

Model	Notes
SDIN	35mm DIN rail mounting bracket
CHF-100B	Current sensor, 100A, DC~20kHz, output $\pm 4v$
CHV-600VD	Voltage sensor, 600V, DC~20kHz, isolated differential input, output $\pm 5v$